

# Analysis of the conversion efficiency and THD of DC/AC converters used in off-grid Photovoltaic generation system

Análisis de la eficiencia de conversión y THD de convertidores DC/AC empleados en un sistema de generación fotovoltaica aislado de la red

J. Fernández Zorro  ; N. J. Rodríguez Ballesteros  ; E. W. Suarez Chaparro  

DOI: <https://doi.org/10.22517/23447214.24807>

Scientific and technological research paper

**Abstract**— This article presents an experimental analysis of the conversion efficiency and total harmonic distortion (THD) of two DC/AC converter prototypes designed for off-grid photovoltaic generation systems (OPGS). The objective is to determine the influence of two controllable factors; the DC input voltage and the percentage of nominal load at the output, on the converters' performance. The prototypes, based on unipolar SPWM modulation, were implemented using simulation software, and tested under a factorial experimental design. The study applied statistical methods, including ANOVA, to analyze the effect of each factor and their interaction on the two response variables: efficiency and THD. Results showed that for the first prototype, efficiency is independent of DC input voltage but dependent on load, while THD is influenced by both factors. In the second prototype, both efficiency and THD are affected by variations in both factors, with THD showing instability due to LC network resonance. The comparison reveals that locating the LC filter after the transformer slightly improves THD but reduces efficiency due to increased harmonic losses. These findings are relevant for optimizing inverter design in isolated PV systems.

**Index Terms** —Efficiency, Experimental Design, Inverter, Photovoltaic System, Total Harmonic Distortion.

**Resumen**— Este artículo presenta un análisis experimental de la eficiencia de conversión y la distorsión armónica total (THD) de dos prototipos de convertidores DC/AC diseñados para sistemas de generación fotovoltaica aislados de la red (OPGS). El objetivo es determinar la influencia de dos factores controlables, el voltaje DC de entrada y el porcentaje de carga nominal conectada a la salida sobre el desempeño de los convertidores. Los prototipos, basados en modulación SPWM unipolar, fueron implementados mediante software de simulación y evaluados bajo un diseño experimental factorial. Se aplicaron métodos estadísticos, incluyendo ANOVA, para analizar el efecto de cada factor y su interacción sobre las dos variables de respuesta: eficiencia y THD. Los resultados mostraron que, para el primer prototipo, la eficiencia es independiente del voltaje DC de entrada pero dependiente de la carga, mientras que la THD está influenciada por ambos factores. En el segundo prototipo, tanto la eficiencia

como la THD se ven afectadas por las variaciones de ambos factores, y la THD presenta inestabilidad debido a la resonancia de la red LC. La comparación revela que ubicar el filtro LC después del transformador mejora ligeramente la THD, pero reduce la eficiencia debido a mayores pérdidas por armónicos. Estos hallazgos son relevantes para optimizar el diseño de inversores en sistemas fotovoltaicos aislados.

**Palabras clave** — Diseño experimental, Eficiencia, Inversor, Sistema fotovoltaico, (Distorsión armónica total).

## I. INTRODUCTION

DC/AC converters, also called inverters, are subsystems commonly used to convert direct current (DC) into alternating current (AC), with applications in motor control, energy conversion, and renewable energy systems [1]. Photovoltaic (PV) generation systems, whether grid-connected or off-grid, rely on these converters to adapt solar energy to the requirements of electrical loads and to enable efficient energy management [2]. Due to increasing global energy demand and the environmental impact of traditional power generation methods, photovoltaic systems have become more relevant. Since inverters are central to these systems, it is essential to study their conversion efficiency and the quality of the output power they deliver [3].

Recent studies have analyzed the performance of different inverter topologies, considering aspects such as switching techniques, filter configurations, and control strategies. For instance, transformer-less designs and LC filter placement have shown significant effects on total harmonic distortion (THD) and energy losses [3][4]. Some authors have explored the influence of DC input voltage and load variation on inverter performance, highlighting the role of design parameters on harmonic behavior and efficiency [5]. In particular, Rampinelli et al. [7] proposed mathematical models that relate inverter efficiency to input voltage and output power, demonstrating

Johan Andrés Fernández is affiliated with Future Solutions Development S.A.S., OTTIS HARDWARE Department, Sogamoso, Colombia (e-mail: andresjzfz10@gmail.com).

Nairo Julián Rodríguez is affiliated with SENA, SENNOVA Research Group, Sogamoso, Colombia (e-mail: njrodriguez43@misena.edu.co)

This manuscript was submitted on June 30, 2024, accepted on June 15, 2025, and published on June 30, 2025.

Elkin Wbeimar Suarez is affiliated with Future Solutions Development S.A.S., OTTIS HARDWARE Department, Sogamoso, Colombia (e-mail: elkinsuarezews@gmail.com).



good accuracy for grid-connected PV systems. Similarly, Farfán and Massen [15] evaluated two mathematical approaches to model how variations in input voltage affect conversion efficiency, supporting the importance of this variable in experimental analysis. Likewise, Gallego-Gómez et al. [8] analyzed conduction losses in SPWM-modulated inverters, providing a mathematical formulation that links internal power losses to efficiency degradation. Similarly, Lázaro Campo [12] analyzed the performance of photovoltaic installations in relation to inverter operation and final energy yield, highlighting the importance of matching design parameters to specific environmental conditions. Moreover, comprehensive reviews have compared the behavior of single-phase inverters in photovoltaic applications, providing insights for optimizing topology selection based on THD limits and energy quality standards [1][2]. Additionally, Beltrán Telles et al. [9] carried out an experimental evaluation of H-bridge inverters using SPWM, demonstrating that harmonic distortion and waveform quality are significantly affected by switching strategies and load variations—an aspect that closely aligns with the objectives of this study.

Beyond mathematical modeling, experimental analysis remains a fundamental tool for understanding system behavior under controlled conditions. An experiment involves varying input parameters to observe their influence on selected response variables. However, many experimental efforts rely on trial-and-error methods, which often lack the structure required for drawing reliable and reproducible conclusions. A more rigorous and effective approach involves the use of Experimental Design [6][11], which offers a statistically supported framework for identifying and quantifying the effects of key factors on system performance.

This research applies an Experimental Design methodology to analyze the conversion efficiency and THD of two unipolar SPWM DC/AC converter prototypes implemented via simulation software. Similar approaches have been used in studies of converter performance for UPS applications, where simulation environments enable detailed control and comparison of circuit configurations [14]. The study considers the DC input voltage and the percentage of nominal load at the output as influencing factors. Based on these, null and alternative hypotheses are formulated for each response variable and evaluated through ANOVA statistical analysis.

This paper is organized as follows: Section II presents the design and definition of factors; Section III details the simulation methodology; Section IV discusses the results; and finally, Section V provides the main conclusions.

## II. CONSTRUCTION OF THE EXPERIMENTAL DESIGN

The Experimental Design is structured under the guidelines shown in Fig. 1.

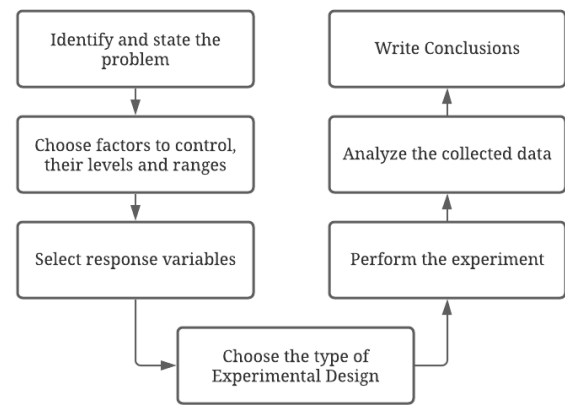

Fig. 1. General guidelines for designing an experiment [7].

### A. Identify and state the problem

The problem consists in determining the influence of the DC voltage applied to the inverter input and the percentage of nominal load connected to its output, on the conversion efficiency and the total harmonic distortion. For this, it is essential to determine the set of tests to be applied, the way to apply them, and the way to collect and analyze the data. Fig. 2, presents the DC/AC converter under investigation, which belongs to an OPGS and uses unipolar SPWM modulation.

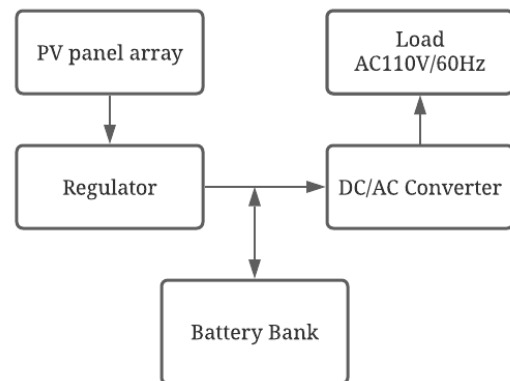

Fig. 2. Block diagram of an OPGS. Source: own

### B. Choose factors to control, their levels and ranges

Different types of variables or factors intervene in every process, such as those shown in Fig. 3. The response variables generally coincide with the output variables of the system and are used to measure its performance and evaluate the effect of the experiment. The controllable factors are the input variables of the process, over which there is control, for this there must be a mechanism that allows the experimenter to change or fix their levels. The uncontrollable factors, also called noise, correspond to those input variables over which there is no control, such as physical, environmental or inherent phenomena to the process and that appear randomly, affecting its behavior. [8].

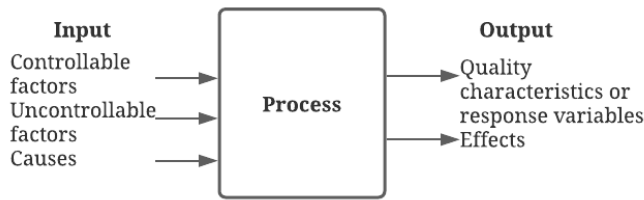

Fig. 3. Variables involved in a process. Based on [8].

Table I shows the most relevant considerations when sizing an OPGS. Taking into account that the DC / AC converter (inverter) is the study center of this research, aspects such as the voltage of the battery bank, the nominal power, the efficiency, the THD and the type of load to be fed, are of great interest.

In accordance with [9], one of the most important parameters and that best represents the operation of a PV inverter is its efficiency curve. Efficiency ( $\eta_{inv}$ ), is the ratio between the energy delivered to a load and the energy required by the inverter. As the inverter is a central block in an OPGS, the efficiency curve provides decisive information for its sizing.

THD is an important variable in electricity generation systems, since it indicates the quality of the energy that is being delivered to the load. The harmonics produced by PV inverters can generate problems within an OPGS, reducing the useful life of electronic devices, therefore, the study of harmonics from THD measurements is crucial [10].

Inverter's efficiency, lies according to operation point on it works. Depending of supplied rated power ( $P_{OAC}$ ) and ( $V_{DC}$ ), we obtains the efficiency that is calculated through (1), where  $F_p$  is the power factor,  $V_{rms}$  is the effective voltage of the inverter,  $I_{rms}$  is the effective current an  $I_{DC}$ , is the average current supplied for the DC source [9].

$$\eta_{inv} = \frac{P_{OAC}}{P_{inDC}} = \frac{V_{rms} \cdot I_{rms} \cdot F_p}{V_{DC} \cdot I_{DC}} \quad (1)$$

On an inverter, the THD of the voltage wave ( $THD_V$ ) and of the current wave ( $THD_i$ ) can be analyzed, these parameters generally depend: of the type of inverter, of the filters used, of the linearity of the load and of the rated power supplied, and it is calculate using (2), where  $V_1$ , is the effective value of the fundamental harmonic.

$$THD_V = \sqrt{\left(\frac{V_{rms}}{V_1}\right)^2 - 1} \quad (2)$$

Table II, shows a resume of the variables that interact on a DC/AC converter. Taking into account the information provided on the Fig. 3, it can be considered as controllable factors [11]: The DC voltage applied in the input, the load connected on the output and the type of load. As response variables, can be chosen: converter's temperature, the conversion efficiency and the THD on the voltage wave of the output. Exist other no controllable variables as the electromagnetic noise, generated both by the converter and by external agents, and the climatic conditions.

For this research, the controllable factors chosen are: the DC voltage applied on the input of the inverter and load's percentage connected on the output, considering for the analysis purely resistive loads. For the first factor, 6 levels are chosen and for the second 10 levels[3] [12]. On the other hand, no controllable factors are neglected, and the efficiency and THD of the voltage wave are considered as response variables.

### C. Choose Experimental Design Type

There are many types of experimental designs to study different problems or situations, however, there are five aspects that influence when choosing one or the other, these are: the objective of the experiment, the number of factors to study, the number of levels that The effects to be investigated and the cost, time and desired precision are tested on each factor [8].

For this research a factorial type experimental design are choose, whose main characteristics are presented on Table III Table IV shows the levels assigned to the controllable factors. In the case of DC voltage, 6 voltage levels are proposed that are within the expected range for the most common battery banks. For the output load, 10 levels expressed as a percentage of the nominal power of the inverter under test were established.

Taking in account that are raised a experimental design with two controllable factors, we propose the next nulls hypotheses:  $H_{01}$ : The efficiency conversion, as well as the THD are independents of DC voltage variation at input of the inverter.  $H_{02}$ : The efficiency conversion, as well as the THD are

TABLE I  
VARIABLES THAT INTERACT IN A DC/AC CONVERTER

Variable	Characteristic
Input DC Voltage (V)	Controllable Factors
Load connected to the output (% of nominal)	
Type of load R-L-C	
Converter Temperature (°C)	Response Variables
Conversion Efficiency(%)	
THD on output voltage (%)	
Electromagnetic noise	Non Controllable Variables
Climatic conditions	

Variables: DC = Direct Current; AC = Alternated Current; V = Voltage,  $\eta$  = Conversion Efficiency; THD = Total Harmonic Distortion ; °C = Celsius degrees, Load Types; R = Resistive; L = Inductive; C = Capacitive

TABLE II  
CONSIDERATIONS WHEN SIZING AN OPGS

Variable	Characteristic
PV array	Morphology – Distribution – Angle of incidence– Distance to battery bank
Battery Bank	Technology – Backup time – Voltage – Connection
Commercial power grid	Availability – Voltage – Frecuency
Charge regulator	Availability – PWM – MPPT
Inverter	Type – Rated power – Temperature – Efficiency – THD
Load	Type (R, C, L) – Linear - Nonlinear - Consumption

Types of solar regulators: PWM = Pulse Width Modulation; MPPT = Maximum Power Point Tracker.

Most common types of loads: R = Resistive; C = Capacitive; L = Inductive; or combinations R-L-C.

Types of photovoltaic systems: GCPS = Grid Connected Photovoltaic System; OPS = Off – Grid Photovoltaic System.

independent of nominal load percentage connected at the inverter output.

$H_{03}$ : The efficiency conversion, as well as the THD are independent of DC voltage variation at the inverter input and the nominal load percentage connected at it's output.

The same way, the following alternative hypotheses are proposed:

$HA_1$ : The efficiency conversion, as well as the THD are dependents of DC voltage variation at inverter input.

$HA_2$ : The efficiency conversion, as well as the THD are dependent of nominal load percentage connected at the inverter output

$HA_3$ : La eficiencia de conversión, así como la THD son dependientes de la variación del voltaje DC a la entrada del inversor y del porcentaje de carga nominal conectada a su salida.

In the next section the methodology employed for apply the proposed experimental design are presented.

III. METHODOLOGY FOR EXPERIMENTAL DESIGN EXECUTION

For this research are proposed two DC/AC converters that's use unipolar SPWM modulation, and that are designed for a nominal power of 2KVA. There block diagrams are shown in the Fig. 4 and Fig.5, respectively.

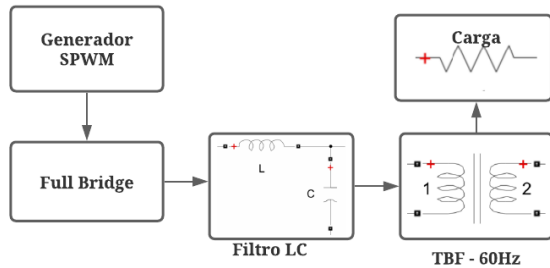

Fig. 4. Block diagram of first prototype DC/AC converter. Source: own

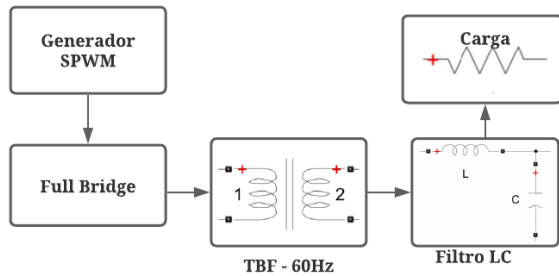

Fig. 5. Block diagram of second prototype DC/AC converter. Source: own

these prototypes were implemented using Matlab tool simulink simulation software[13], taking in account real parameters both in the Full bridge and in transformer , just with difference of LC network positioning [14][15]. with this prototypes ,are searching too , analyse the effect of LC network positioning ,about their performance and energy quality.

For apply the experimental design ,we follow the scheme shown below, at Fig. 6.

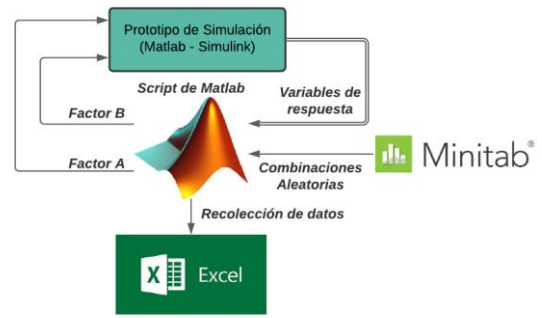

Fig. 6. Employed method for experimental design validation. Source:own

First, the 120 random runs were obtained using the Minitab software, taking into account that there are two controllable factors each with 6 and 10 levels and two repetitions during the experiment. Subsequently, a Matlab script was developed that works in conjunction with Simulink, modifying the values of each input factor according to the runs obtained in the previous step and collecting the data referring to efficiency and THD for each combination. Using the script, you get an array of data that is then exported and organized in a spreadsheet. Finally, an

TABLE III  
CHARACTERISTICS OF PROPOSED EXPERIMENTAL DESIGN

Item	Value/Designation
Controllable Factors	2
Levels	6 y 10 respectively
Response Variable	2
Number of base runs	60
Specimens	2
Replicas	2
Randomness	Si
Number of total runs	240
Data to Collect	480

1. Controllable Factor: What can be varied during experiment
1. Level: Value that takes a controllable factor
2. Response Variable: what is case of study
3. Run: Combination of the factors
4. Specimens: Experimental unit

TABLE V  
AVERAGE VALUES OF EFFICIENCY OF PROTOTYPE I

Controllable Factors	Factor A						
	22	23.6	25.2	26.8	28.4	30	
Factor B	10	96.486	96.484	96.481	96.479	96.522	96.514
	20	96.728	96.692	96.691	96.69	96.688	96.719
	30	96.139	96.152	96.111	96.11	96.143	96.136
	40	95.371	95.346	95.382	95.38	95.376	95.343
	50	94.537	94.516	94.55	94.549	94.514	94.514
	60	93.681	93.664	93.697	93.696	93.692	93.662
	70	92.822	92.829	92.837	92.839	92.837	92.806
	80	91.963	91.968	91.978	91.949	91.978	91.977
	90	91.111	91.117	91.127	91.128	91.128	91.126
	100	90.271	90.263	90.285	90.29	90.263	90.289
Media:	93.97	Standard Deviation: 2.2			Variance: 4.84		

Controllable Factors: A = DC voltage at the input of the DC / AC Converter in volts (V); B = Percentage of nominal load connected to the output of the DC / AC Converter (%). Response variable: Conversion efficiency (%).

ANOVA analysis of variance is carried out and the main

effects and interaction graphs for each response variable and the normal probability graph are obtained. The results obtained are examined in detail in the following Section.

#### IV. RESULTS

Table V, presents the average values of efficiency conversion of the first prototype, related to each of the runs or combinations that were applied during the experiment.

It can be seen that the average efficiency of this prototype is 93.97%, on the other hand, the standard deviation shows that the data is relatively homogeneous, since there is a separation from the mean. The Fig. 7, show the main effect of each of the factors about conversion efficiency of prototype I.

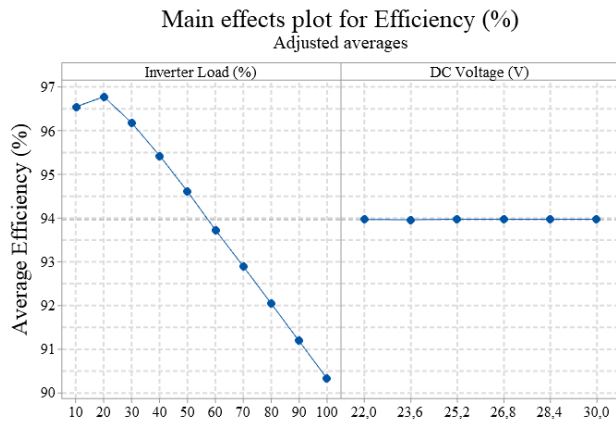

Fig. 7. Main effects graph for the efficiency of the prototype I. Source: own

At first glance, the efficiency compartment is not affected by variations in DC voltage, while the load percentage, if it has an effect on it, and is as mentioned in Section II, since, depending on the point inverter work, there is a different value for efficiency. Efficiency presents this behavior, because, as the load connected to the inverter increases, the current flowing through the switches, conductors and transformer also increases, the rising current increases the switching losses, due to the joule effect and due to the harmonics present, and according to the slope of the graph, these losses are not negligible. The Fig. 8, shown the effect produce for interaction of the both factors about efficiency.

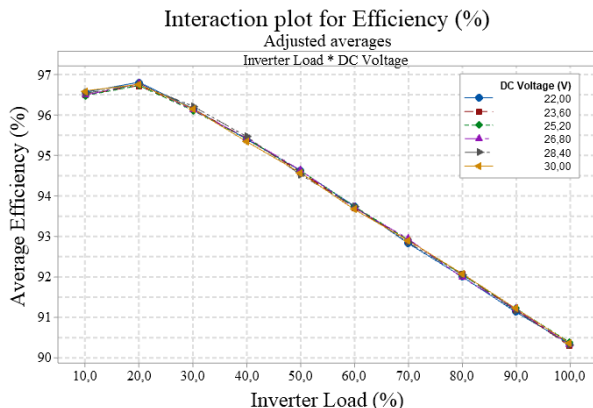

Fig. 8. Efficiency curves of prototype I. Source: own

In this graph, it can be noticed clearly, that's DC voltage, doesn't have a significant effect over efficiency curve of the DC/AC converter, this can be explained from harmonics point of view, generated by used modulation required to obtain the sinusoidal equivalent waveform at the output. The harmonics generated in this type of systems, depends of many factors, among them, DC input voltage, tuning of LC network [14] [15], Switching frequency of full bridge, index amplitude modulation among others. The harmonics in general produce power losses in all elements that transport them, but for a OPGS, The power losses increase in the isolation transformer [16], For this reason, placing the LC filter behind the primary one prevents harmonics from being conducted by the transformer, for this reason, when the load remains constant and the DC voltage varies, the amplitude of the harmonics may change; however, they are not present at the transformer primary. As a result, the associated power losses are not reflected in the efficiency.

On the other hand, the interaction graph drives that's for a nominal load of 100%, obtains a minimum efficiency of 90.5% approximately, whereas a load of 20%, the efficiency reaches its maximum value of 96.7%. The optimum operation point for this system is located around 50% of load, at this point we can extract the maximum power at a related good efficiency, this information is useful for implement OPGS, and analyse the different circumstances of operation of this important block.

Applying a statistical analysis ANOVA, can be determined with certainty, if the null hypotheses, exposed on the Section II are true and they must be accepted or, conversely, rejected. Table VI, shows the ANOVA for the efficiency of the prototype I.

Observing the values P, of each one of the factors of individual way of each of the factors individually and their interaction, It

TABLE VI  
ANOVA FOR EFFICIENCY OF PROTOTYPE I

Source	DF	SS	MS	Valor F	Valor P
Inverter Load (%)	9	573.21	63.69	8246.5	0.000
DC Voltage (V)	5	0.002	0.0004	0.05	0.998
Inverter Load (%) * DC Voltage (V)	45	0.145	0.0032	0.42	0.999
Error	60	0.463	0.0077		
Total	119	573.82			

Statistical Terms: DF = Degrees of Freedom; SS = Sum of Squares; MS = Mean Square.

can be stated that the conversion efficiency of prototype I is dependent on the percentage of nominal load connected to its output and independent of the variation of the DC voltage applied to the input, and also independent of their interaction.

Fig. 9, presents the graphic of normal probability of obtained data for the efficiency. Considering a significance level of 0.05, it can be said that most of the data follow the adjusted distribution line and their behavior is normal.

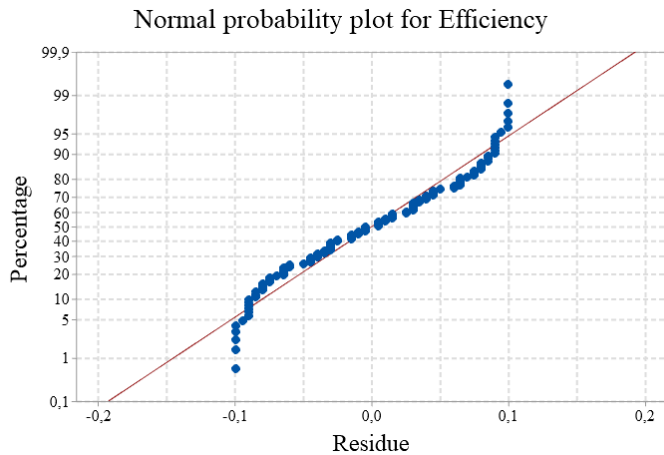

Fig. 9. Normal probability plot for the efficiency of the prototype I. Source: Own

Table VII, shows the average values of the THD of the voltage wave of prototype I. According to international standards such as IEEE519 or EN50160, the levels of total harmonic distortion must be less than 8%, for systems whose supply voltage is less than 1000V, in this way it is ensured that harmonics do not cause considerable damage. sensitive electronic devices. According to Table VII, the average THD for prototype I is 0.0461%, which is much less than 1%, as expected, when considering linear and purely resistive loads, however, this information serves to check the waveform output of prototype I.

Fig. 10, shows the response of the THD in front of individual variations of the controllable factors. According to this graphic, the THD depends both the DC voltage and the percentage of connected load. It is observed that for a load level between 10% and 90%, the THD varies proportionally with the load, this behavior is due to the resonant effect of the LC network, which causes an increase or decrease in harmonics, close to the resonant frequency.

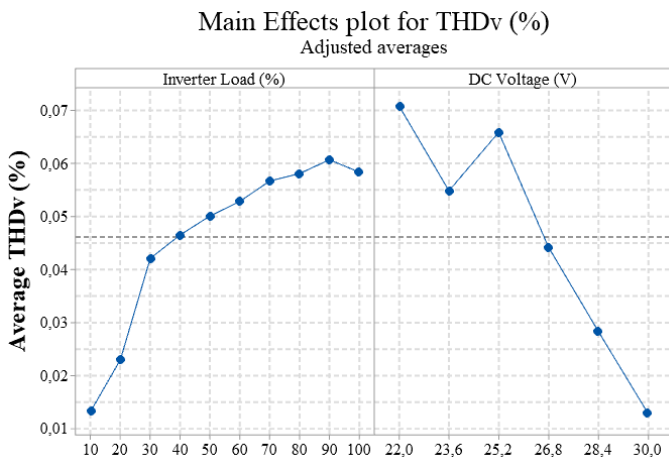

Fig. 10. Main effects plot for the THD of prototype I. Source: Own

Fig. 11 shows the interaction graph for the THD of the prototype I. With this graph, it can be clearly seen that the DC

TABLE VII  
AVERAGE THD VALUES IN PROTOTYPE I

Controllable Factors	Factor A						
	22	23.6	25.2	26.8	28.4	30	
Factor B	10	0.033	0.0012	0.01	0.001	0.004	0.001
	20	0.058	0.005	0.051	0.003	0.002	0.002
	30	0.059	0.064	0.055	0.028	0.016	0.003
	40	0.062	0.063	0.064	0.039	0.023	0.004
	50	0.069	0.06	0.069	0.045	0.021	0.005
	60	0.077	0.057	0.074	0.05	0.033	0.006
	70	0.078	0.063	0.079	0.056	0.034	0.007
	80	0.074	0.067	0.076	0.053	0.037	0.018
	90	0.078	0.065	0.075	0.064	0.042	0.016
	100	0.077	0.058	0.068	0.064	0.036	0.029
Media: 0.0461		Desviación Estándar: 0.027		Varianza: 0.00072			

Controllable Factors: A = DC voltage at the input of the DC / AC Converter in volts (V); B = Percentage of nominal load connected to the output of the DC / AC Converter (%).  
Response variable: THD = Total Harmonic Distortion (%).

voltage has an influence on the THD response, since a different curve is obtained for each value. It is observed that the higher the DC voltage, the better the THD levels are obtained, this is due to the fact that the latter is inversely proportional to the amplitude of the fundamental harmonic, which is proportional to the input voltage [1].

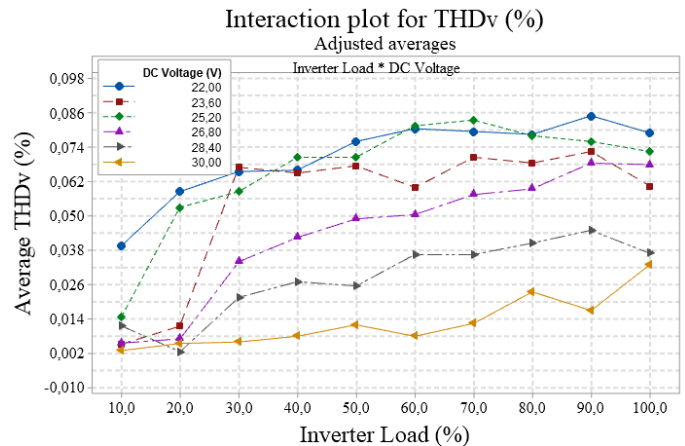

Fig. 11. THD Curves of prototype I. Source: Own

Table VIII, shows the ANOVA for THD of prototype I. Observing the P values, of each of the factors individually and their interaction, we can say, THD of prototype I, is dependent of nominal load percentage connected to output and dependent of variation of DC voltage applied to the input, but it also

TABLE VIII  
THD ANOVA FOR PROTOTYPE I

Source	DF	SS	MS	Value F	Valor P
Inverter Load (%)	9	0.027	0.003	77.36	0.000
DC Voltage (V)	5	0.05	0.010	251.14	0.000
Inverter Load (%) * DC Voltage (V)	45	0.008	0.0002	4.68	0.000
Error	60	0.002	0.0000		
Total	119	0.088			

Statistical Terms: DF = Degrees of freedom; SS = Sum of squares; MS = Middle Square.

depends of their interaction.

The Fig. 12, shows the normal probability graph of the THD values obtained during the experiment. According to the chosen level of significance, the experimental data behave according to the normal distribution line, however, there is a variability in the extremes that is common in this type of graph.

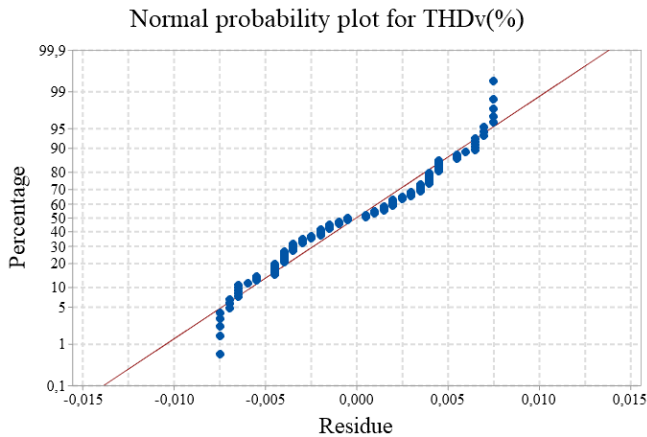

Fig. 12. Normal probability graph for THD of prototype I. Source: own

Next, the hypotheses raised in Section II are validated for this particular prototype.

The hypotheses  $H0_1$ , considers that's the conversion efficiency and the THD, are independents of the variation of DC voltage, although, the results shown that's efficiency are independent of DC input voltage , but THD are dependent, therefore must be rejected both hypotheses  $H0_1$  and  $HA_1$

The hypotheses  $H0_2$ , establish that's conversion efficiency and THD, are independents of nominal load percentage connected to the output inverter, however, the results shown both efficiency and THD , are depend of load percentage, by the arguments mentioned before the null hypotheses  $H0_2$  are rejected but the alternate hypotheses are confirm  $HA_2$

The hypotheses  $H0_3$ , assert efficiency conversion and THD, are independents of interaction between DC voltage and load percentage, however, the results allow assert efficiency is independent of there interaction, but THD is dependent. En this case, should be rejected both hypotheses, null  $H0_3$ and alternate  $HA_3$ .

Following, the same analysis is performed for conversion efficiency and THD of prototype II

The Table IX, shows the average values of conversion efficiency of prototype II, related with each combinations applied during experiment.

According to the results, the prototype II has an average efficiency of 93.73%, approximately 0.24% lower than that of prototype I. This is explained by the additional losses caused by high-frequency harmonics when the LC network is placed on the secondary side of the transformer. This observation is consistent with the findings of Gerardo and Miguel [10], who reported that post-transformer LC filters improve harmonic suppression but also introduce additional switching and conduction losses, slightly reducing overall efficiency. It is also observed that the data obtained are homogeneous, as in

TABLE IX  
EFFICIENCY AVERAGE VALUES OF PROTOTYPE II

Controllable Factors	Factor A						
	22	23.6	25.2	26.8	28.4	30	
Factor B	10	96.081	95.971	95.861	95.752	95.644	95.531
	20	96.486	96.43	96.374	96.317	96.262	96.207
	30	95.971	95.933	95.895	95.858	95.821	95.784
	40	95.231	95.207	95.179	95.151	95.122	95.093
	50	94.422	94.399	94.374	94.356	94.329	94.31
	60	93.58	93.56	93.535	93.523	93.504	93.487
	70	92.727	92.713	92.693	92.665	92.666	92.65
	80	91.872	91.86	91.846	91.814	91.816	91.801
	90	91.025	91.01	91.002	90.991	90.979	90.961
	100	90.186	90.179	90.169	90.159	90.147	90.13
Average: 93.73		Standard Deviation: 2.092		Variance: 4.38			

Controllable Factors: A = DC voltage at input DC/AC converter, volts (V);  
B = Nominal load Percentage connected to DC/AC Converter (%).  
Response Variable: Efficiency conversion (%).

prototype I, according to the standard deviation..

The Fig. 13, shows the individual effect of every factor over conversion efficiency of prototype II.

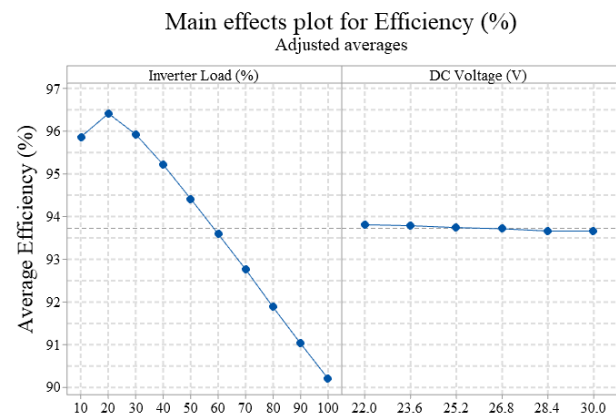

Fig. 13. Main effects plot for the efficiency of the prototype II. Source: Own

According to this graphic, both the DC voltage and the load percentage have an influence on the performance of the converter. In the case of efficiency, the same thing happens as in prototype I, since for each load value, there is a different efficiency. According to Fig. 13, the lowest efficiency is 90.13% and occurs when 100% of the load is connected, on the other hand, the maximum efficiency is 96.48% and like the prototype I, occurs for a 20% load. It is also observed that the DC voltage is inversely proportional to the efficiency, this is due to the fact that when the DC voltage increases, the mplitudes of the harmonics also increase, generating greater losses in the transformer.

Fig. 14, shows the effect that have the interaction of the two factors on the efficiency. According to this graphic, the effect of the interaction is remarkable for load levels lower than 50% , Despite of that, does not exist a big difference between one curve and the other, the largest difference is 0.5% and occurs for a 10% load, on the other hand, the maximum efficiency occurs for a DC voltage of 22V and a load level of 20%, the

worst efficiency occurs for a DC voltage of 30 V and a load level of 100% and the optimum operating point appears around 50% of the load.

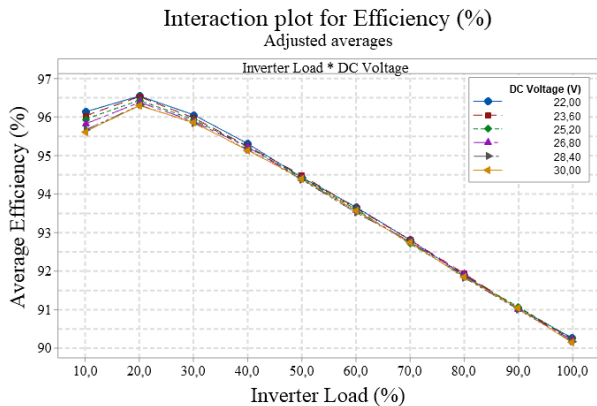

Fig. 14 Prototype II efficiency curves. Source: Own

TABLE X

ANOVA FOR THE EFFICIENCY OF THE PROTOTYPE II

Source	DF	SS	MS	Value F	Value P
Inverter Load (%)	9	520	57.78	9146.89	0.000
DC Voltage (V)	5	0.387	0.0773	12.24	0.000
Inverter Load (%) * DC Voltage (V)	45	0.329	0.0073	1.16	0.296
Error	60	0.379	0.0063		
Total	119	521.16			

Statistical Terms: DF = Degrees of Freedom; SS = Sum of Squares; MS = Mean Square.

Table X shows the ANOVA for the prototype II conversion efficiency

Observing the P values of each of the factors individually and their interaction, it can be ensured that the efficiency of the prototype II is dependent on the percentage of load and the variation of the DC voltage applied to the input, but it is independent of their interaction, as shown in Fig. 14.

Fig. 15, shows the graphic of normal probability for the efficiency of prototype II. Likewise, for a significance level of 0.05, it can be stated that the data follow the normal distribution line and that its behavior is as expected.

Normal probability plot for Efficiency (%)

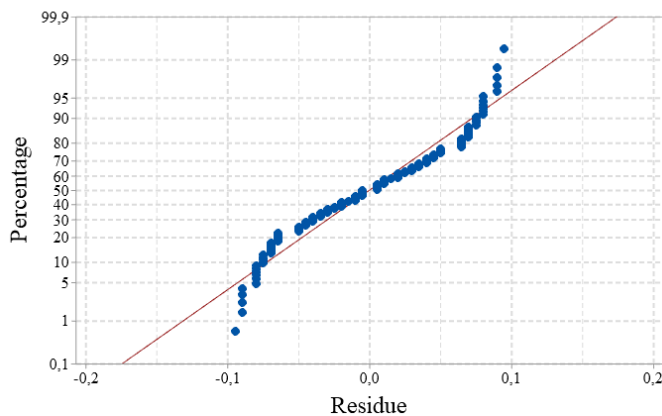

Fig. 15. Normal probability plot for the efficiency of the prototype II. Source:

Own.

Tabla XI, presents the data of the THD produced by the prototype II. This second prototype has an average THD of 0.019% and according to the standard deviation, the data is less dispersed than in prototype I. Note that the amount of harmonics generated by prototype II is relatively less than that of prototype I, this is due to the location of the LC filter.

Fig. 16, presents the main effects plot for the prototype II THD. The behavior of the THD against load variations is different than in the prototype I, first, because its levels are below 0.035% and second, because between 30% and 90%, it is unstable. This unstable behavior is due to the resonance effect of the LC filter, which depends on the connected load [14] [15]. Note that there is an inversely proportional relationship between DC voltage and THD, for the same reason as in prototype I.

TABLA XII

ANOVA PARA LA EFICIENCIA DEL PROTOTIPO II

Fuente	DF	SS	MS	Valor F	Valor P
Inverter Load (%)	9	0.007	0.0008	1830.56	0.000
DC Voltage (V)	5	0.025	0.005	11346.6	0.000
Inverter Load (%) * DC Voltage (V)	45	0.013	0.0003	658.1	0.000
Error	60	0.0003	0.0063		
Total	119	0.045			

Statistical Terms: DF = Degrees of Freedom; SS = Sum of Squares; MS = Mean Square.

Main Effects plot for THDv (%)

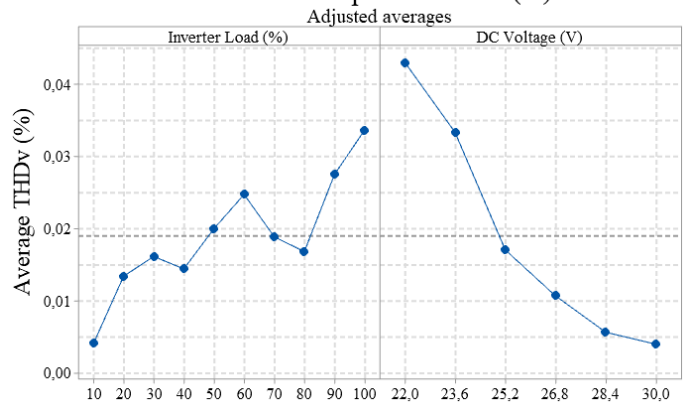

Fig. 16. Main Effects Plot for Prototype II THD. Source: Own.

Fig. 17, shows the interaction graph between the factors, where it can be clearly seen that both have an influence on the THD response.

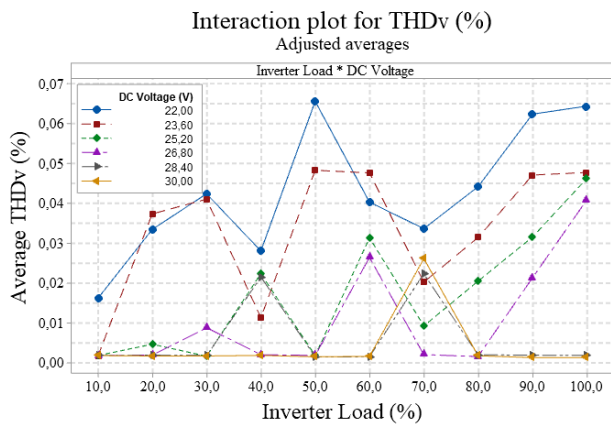

Fig. 17. THD curves of the prototype II. Source: Own

Similarly, it is observed that the THD presents an unstable behavior, for load values between 30% and 90% of the nominal, product of the resonant frequency of the LC filter. Note that for a DC voltage of 30 V, lower THD values are obtained, while for a voltage of 22 V, higher values are obtained. As future work, it is proposed to find a solution to the instability of these systems.

Table XII, shows the ANOVA for the THD of prototype II. Observing the P values of each of the factors and their interaction, it can be ensured that the THD of the prototype II is dependent on both the load percentage and the DC voltage, and also depends on their interaction, such as was shown in Fig. 17.

Fig. 18, shows the behavior of the collected data against the normal distribution line. This graph shows how the data tries to follow normality, but there is an oscillation, due to the instability of the response.

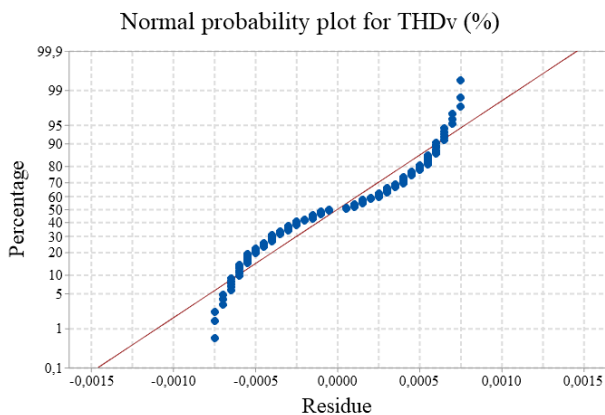

Fig. 18. Normal probability plot for the prototype II THD. Source: Own

Next, the hypotheses raised in Section II are validated for this particular prototype.

The hypothesis  $H_{01}$ , It considers that the conversion efficiency and the THD are independent of the variation of the DC voltage, however, the results show that both the efficiency and the THD are dependent on the DC voltage. Therefore, the null hypothesis  $H_{01}$  is rejected and the alternate  $H_{A1}$  is accepted.

The hypothesis  $H_{02}$ , establishes that conversion efficiency ,

such as the THD, are independent of load percentage, nevertheless, the results show that both efficiency and THD, are dependent of load percentage, for that reason, the null hypothesis  $H_{02}$  is rejected and the alternate hypothesis  $H_{A2}$  is accepted.

The hypothesis  $H_{03}$ , affirms that conversion efficiency and the THD, are independent of interaction between DC voltage and load percentage, however, the results allow to affirm, that efficiency is independent of their interaction, but the THD is dependent. In this sense, both the null hypothesis  $H_{03}$ , and the alternate hypothesis  $H_{A3}$  are rejected.

The results obtained in this study align with and expand upon recent findings in the literature related to inverter performance in photovoltaic applications. For instance, the observation that the THD is significantly affected by both DC input voltage and output load is consistent with the analysis reported by Bouzguenda and Selmi [4], who emphasized the sensitivity of harmonic content to inverter design parameters and load conditions. Similarly, the higher efficiency observed when the LC filter is placed at the transformer’s primary supports the conclusions of Shrestha et al. [3], who showed that minimizing transformer-conducted harmonics is key to reducing losses in transformer-based topologies.

Compared to the work of Albakri et al. [1], who provide a comprehensive overview of inverter designs, this study adds experimental insight by using a factorial design to quantify how controllable factors affect efficiency and harmonic distortion. Additionally, the THD levels achieved in both prototypes (under 1%) are in line with international standards such as IEEE 519 and EN 50160, validating the models under linear and resistive load assumptions —as also noted by Chaurasia and Singh [5] in their work on multilevel inverters.

Moreover, the instability observed in the THD under certain load conditions in prototype II may be associated with the resonant behavior of LC filters, as discussed in previous studies [2]. In particular, Horikoshi [13] examined how harmonic components originate and propagate in grid-connected photovoltaic inverters, emphasizing that both the selection and positioning of filter elements significantly influence waveform quality. This underscores the practical importance of not only choosing appropriate filter components but also strategically placing them within the circuit. The experimental methodology applied in this study, grounded in statistical rigor through ANOVA and controlled manipulation of input variables, offers a structured and replicable approach that is rarely found in similar simulation-based analyses, thereby enhancing the study’s value in terms of reliability and applicability..

## V. CONCLUSIONS

It was found that prototype I, the conversion efficiency is dependent on the load variation and independent of the variation of the DC voltage and its interaction, as an effect of placing the LC filter in the primary of the transformer. It was also observed that the THD is inversely proportional to the DC voltage and directly proportional to the load percentage.

It was observed that in the prototype II, the conversion efficiency is affected by the variations of the DC voltage and the percentage of connected load, but it is independent of the interaction of these two factors. On the other hand, the THD, despite being dependent on the DC voltage and the connected load, presents an unstable behavior for loads between 30% and 90% of the nominal power, due to the resonant effect of the LC network.

It was found that by placing the LC filter on the secondary of the transformer, the average efficiency of the converter is reduced because the high frequency harmonics are not attenuated and cause additional losses in the transformer, while the THD levels are slightly reduced.

It was observed that the THD levels obtained with the experiment, are much less than 1%, since during the experiment, it just consider linear loads and purely resistive, however, the analysis carried out provides an idea of how they are going to behave prototypes in front of non-linear loads and how they will affect the variation of the DC voltage and in the percentage of the connected load.

The resonant effect of LC network, generates instability on the response of the THD when it locates on the secondary of transformer, This highlights the need to minimize this effect in order to prevent high-power nonlinear loads from significantly degrading inverter performance and waveform quality.

It was found that by placing the LC filter on the secondary of the transformer, the average efficiency of the converter is reduced because the high frequency harmonics are not attenuated and cause additional losses in the transformer, while the THD levels are slightly reduced. This behavior is consistent with the findings of Gerardo and Miguel [16], who demonstrated that filter location significantly impacts both the harmonic suppression and energy losses in transformer-based inverter configurations

## VI. FUTURE WORK AND CONTRIBUTIONS

The findings of this study provide a solid foundation for future developments in the design and optimization of DC/AC converters for off-grid photovoltaic systems. First, the experimental methodology used —based on factorial design and statistical validation— can be replicated to evaluate other converter topologies, modulation strategies (such as bipolar SPWM, space vector PWM), or filtering techniques. Additionally, the results highlight the importance of LC filter positioning in harmonic mitigation and system efficiency, offering practical guidance for designers seeking to optimize inverter layouts.

In future work, the prototypes could be tested under nonlinear and dynamic loads to simulate more realistic operating conditions. Also, implementing physical prototypes in laboratory settings will allow validation of the simulation results and the quantification of real-world losses, including thermal behavior and electromagnetic interference. Finally, this study opens the door to developing intelligent control systems that automatically adjust operating parameters (e.g., switching frequency, modulation index) based on load conditions, improving energy quality and system reliability in real-time.

By integrating these advances, the study contributes to the continuous improvement of photovoltaic systems, enabling more robust, efficient, and reliable off-grid energy solutions, particularly relevant for rural or remote electrification projects.

## REFERENCES

- [1] M. Albakri, A. Darwish, and P. Twigg, "A Comprehensive Review of DC/AC Single-Phase Differential-Mode Inverters for Low-Power Applications," *\*Electronics\**, vol. 13, no. 13, p. 2474, 2024. <https://doi.org/10.3390/electronics13132474>.
- [2] MDPI Energies, "A Comparative Review of Three Different Power Inverters for DC-AC Applications," *\*Energies\**, vol. 16, no. 21, p. 7254, 2023. <https://doi.org/10.3390/en16217254>
- [3] S. Shrestha et al., "A Comparative Analysis of Transformer-less Inverter Topologies for Grid-Connected PV Systems," *\*arXiv preprint arXiv:2501.08103\**, 2025.
- [4] M. Bouzguenda and T. Selmi, "Review of DC-AC converters for photovoltaic conversion chains," *\*International Journal of Power Electronics and Drive Systems (IJPEDS)\**, vol. 12, no. 2, pp. 886–901, 2021. [https://doi.org/10.1007/978-981-19-7728-2\\_15](https://doi.org/10.1007/978-981-19-7728-2_15)
- [5] R. Chaurasia and S. B. Singh, "Performance Analysis of Multi-level DC-AC Inverter for Solar Power Application," in *\*Recent Advances in Power Electronics and Drives\**, Springer, 2023. [https://doi.org/10.1007/978-981-19-7728-2\\_15](https://doi.org/10.1007/978-981-19-7728-2_15)
- [6] H. Gutierrez and R. De la Vara, *\*Analysis and Design of Experiments\**, 2nd ed., McGraw-Hill, 2016.
- [7] G. A. Rampinelli, A. Krenzinger, and F. Chenlo Romero, "Mathematical models for efficiency of inverters used in grid connected photovoltaic systems," *\*Renewable and Sustainable Energy Reviews\**, vol. 34, pp. 578–587, 2014. <https://doi.org/10.1016/j.rser.2014.03.047>
- [8] J. D. Gallego-Gomez, J. B. Cano-Quintero, and N. Muñoz-Galeano, "Deducción de pérdidas de potencia por conducción en inversores modulación senoidal de ancho de pulso, SPWM," *\*Información Tecnológica\**, vol. 26, no. 3, pp. 111–122, 2015. <https://doi.org/10.4067/S0718-07642015000300015>
- [9] Busso, C. Cadena, and L. Vera, "Determinación de la eficiencia de conversión del inductor empleado en un sistema de generación fotovoltaica conectado a red instalado en el nordeste argentino," *\*Avances en Energías Renovables y Medio Ambiente\**, vol. 15, pp. 17–24, 2011.
- [10] Beltrán Telles et al., "Análisis de calidad de la energía de inductor de puentes H y control SPWM," *\*Ingeniería Energética\**, vol. 41, no. 1, pp. 1–11, 2020.
- [11] D. Montgomery, *\*Design and Analysis of Experiments\**, 8th ed., Wiley, 2012.
- [12] E. Lázaro Campo, *\*Optimización del índice de producción final de una instalación solar fotovoltaica para un inductor y emplazamientos dados\**, Tesis de Maestría, 2012.
- [13] Horikoshi, *\*Análisis de las componentes armónicas de los inversores fotovoltaicos de conexión a red\**, Tesis de Maestría, 2009.
- [14] R. A. da Câmara et al., "Comparative analysis of performance for single-phase AC-DC converters using FPGA for UPS applications," in *\*Proc. IEEE APEC\**, 2013, pp. 1852–1858. <https://doi.org/10.1109/APEC.2013.6520547>
- [15] R. Federico Farfán and C. Wilhelm Massen, "Análisis de dos modelos matemáticos de inversores para el estudio de la variación de la eficiencia de conversión con respecto a la tensión de entrada," 2018. <https://doi.org/10.59627/cbens.2018.281>
- [16] V. Gerardo and S. J. Miguel, "High Efficiency Single-Phase Transformer-less Inverter for Photovoltaic Applications," *\*Ingeniería Investigación y Tecnología\**, vol. XVI, no. 2, pp. 173–184, 2015. <https://doi.org/10.1016/j.riit.2015.03.002>



**Johan Fernández Zorro.** Sogamoso native, Colombia. Received a degree in Electronic Engineering from Universidad Pedagógica y Tecnológica de Colombia, located in Sogamoso, Colombia 2020. He is teacher from Electronic Engineering School from Universidad Pedagógica y Tecnológica de Colombia. He works in Future Solutions Development S.A.S Company as research engineer.

<https://orcid.org/0000-0003-2905-5438>



**Nairo Julian Rodriguez Ballesteros** is an junior researcher at the Sena centro industrial de mantenimiento y manufactura. He works as leader in research group, innovation and applied knowledge of boyaca (GICAB- SENA) in reliability engineering. He received his B.Sc. in electromechanical engineering from Universidad pedagógica y tecnológica de Colombia in 2009 and holds a M.Sc. in engineering- mechanical from the Universidad Nacional de Colombia, (2015). <https://orcid.org/0000-0001-8471-1579>



**Elkin Wbeimar Suarez Chaparro** Sogamoso native, Colombia. Received a degree in Electronic Engineering from Universidad Pedagógica y Tecnológica de Colombia, located in Sogamoso, Colombia Colombia 2017. he is and hardware developer , and amateur embedded programmer , works in Power electronics, oriented to photovoltaic energy appliances, actually he works like senior research at Future Solutions Development S.A.S company.

<https://orcid.org/0000-0002-2721-5605>